

DAPU

**LCD-K Manual for
Trident E Spike**

Contents

About the User Manual	3
External Dimensions	3
Material and Color	3
Function Summary & Button Definition	4
Function Summary	4
Full Display Area	5
Normal Display Area	5
Button Definition	6
Normal Operation	6
1 ON/OFF	6
2 Display Interface	7
3 Push Cruise Control	8
4 Backlight ON/OFF	9
5 Assistance Level Select	9
6 Capacity Display	10
7 Error Code Display	10
General Setting	11
1、 Distance and Riding Time Clearing	11
2、 Wheel Size Setting	11
3、 KM/H, MPH Switching	12
FAQ	13
Quality assurance and Warranty scope	13
Warranty	13
Other items	14
Version Updates	14
Error code definition	15
Table 1	15

About the User Manual

To ensure better performance of your new Trident E Spike , please read through the manual carefully before using it. It will give you all the details including installation and settings and normal use of the Dapu Display. The manual will also help you with troubleshooting any malfunctions should they arise.

Material and Color and Dimensions

LCD- K products are made from Black PVC. They are made to function normally in temperatures ranging from 0 ° to 140° F

Product dimensions are listed below (in MM)

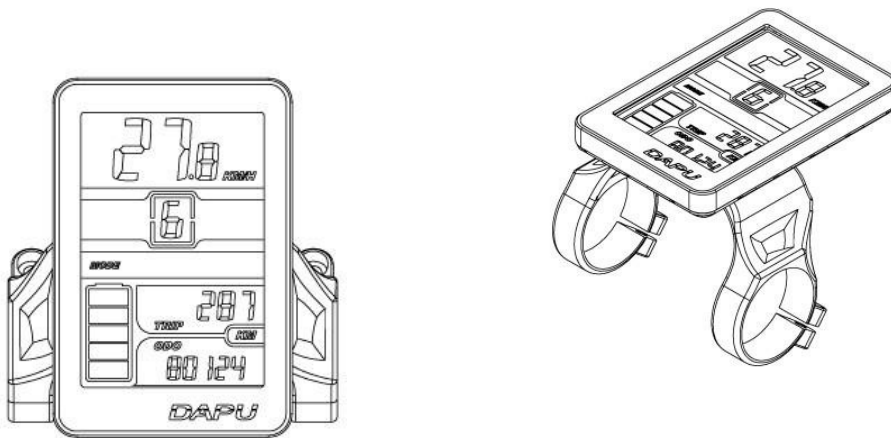

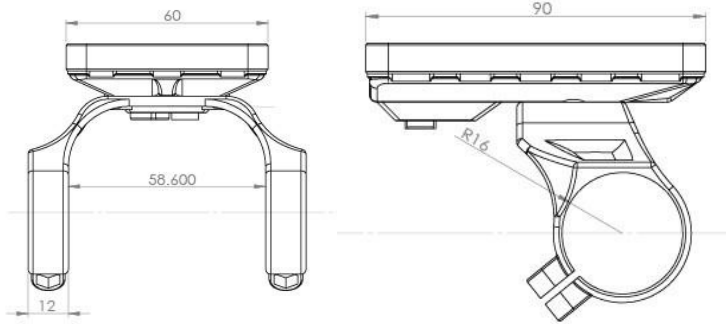

Function Summary and Button Definitions

The LCD Display provides a wide range of functions. The functions are as follows:

- ODO Display;
- Riding Distance Display;
- Speed Display;
- Backlight ON/OFF;
- Assist Level;
- Capacity Display;
- Mode display;
- Error Code Display;
- Wheel Diameter Setting;
- KMH, MPH Switching;

Full Display Area

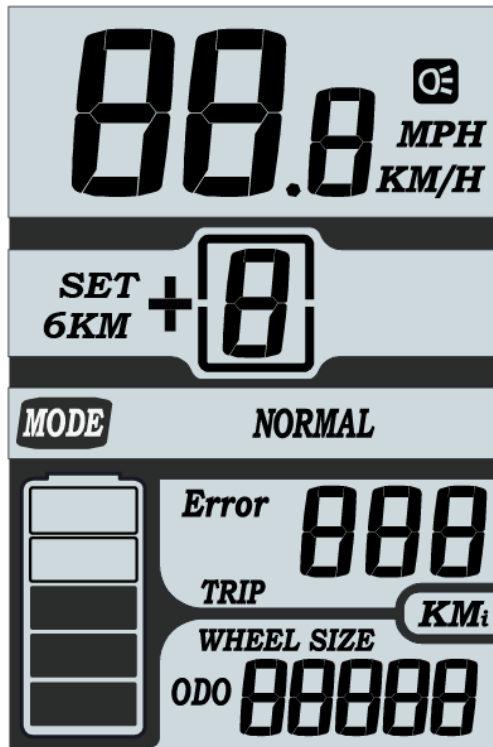

Normal Display Area



Button Definition

There are four buttons on the LCD-K, **ON/OFF**, **SET**, **UP** and **DOWN**.

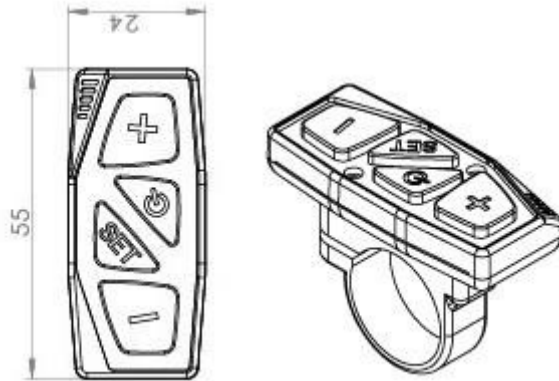

Normal Operation

1. ON/OFF

Pressing the **ON/OFF** button will power up the display. Pushing the power button a second time will backlight the display for nighttime use. Pressing the ON/OFF button for three seconds can turn off the display.

If your E Spike has not been used for five minutes the display will automatically shut down.

If the display is powered up and you have the Parking Brake on you will get an Error 5 message on the Display. This is normal. Squeezing the brake lever will automatically remove the error code.

2. Display Interface

The LCD-K will display speed, Odometer (in whole miles/km) Trip, Assist Level, and Battery Level.

Speed display:

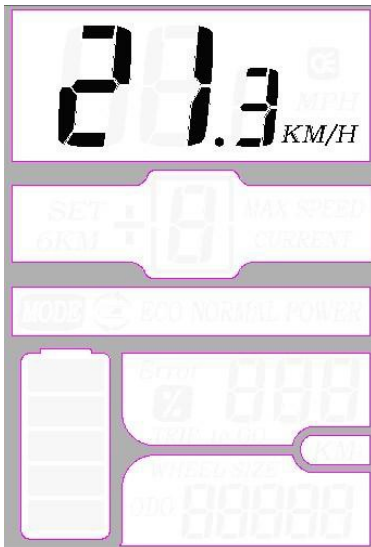

Distance display:

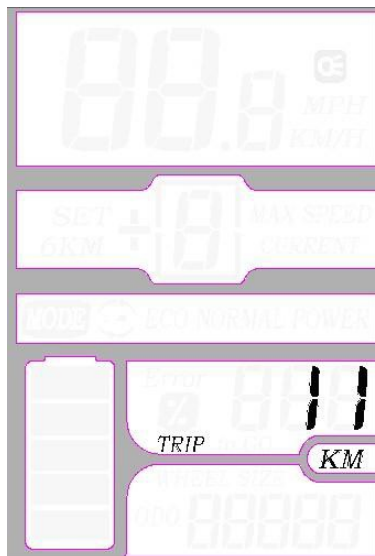
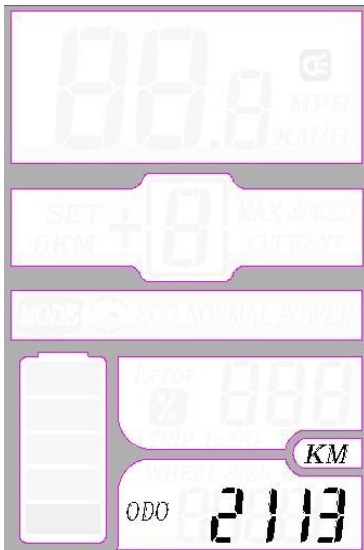

Assist level display:

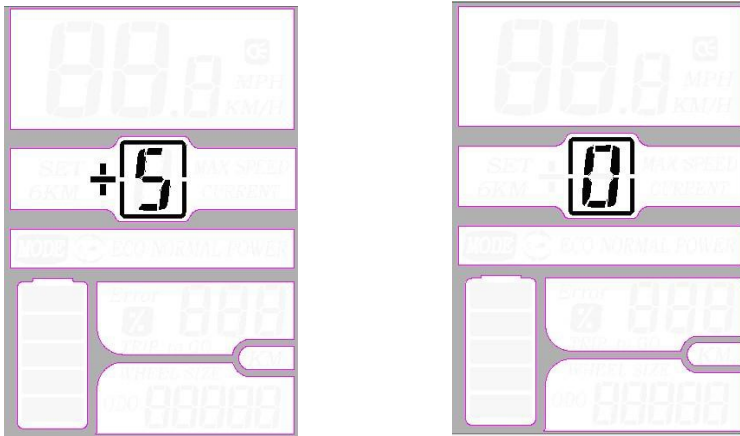

Battery display:

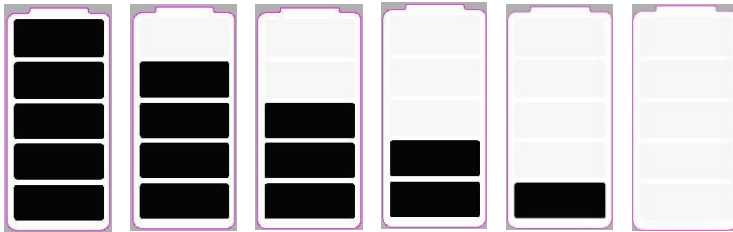

3. Backlight ON/OFF

With the Display on, pressing the **ON/OFF** Button again turns the backlight on and off for nighttime riding.

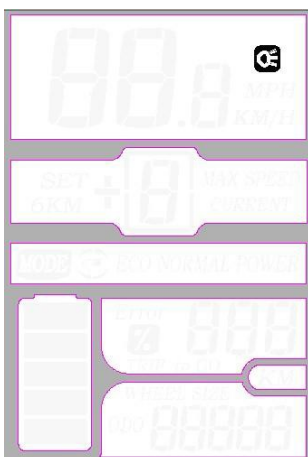

4. Power Assist Level Select

Press **UP** or **DOWN** to change the E Spike Assist Level. You can choose between 0-6 . When the display shows 0 the Throttle on the left handlebar will operate. When you choose 1-6 , the Throttle will no longer operate but you will have different levels of assist. 1 is the least amount of assist 6 is the most. The level will be saved when you turn the display off. You are able to change this setting while moving.

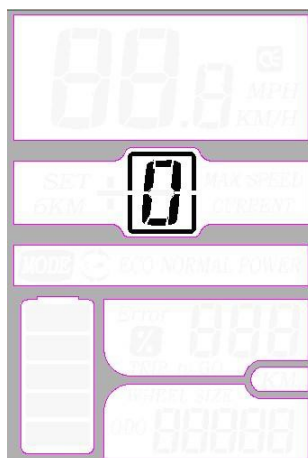
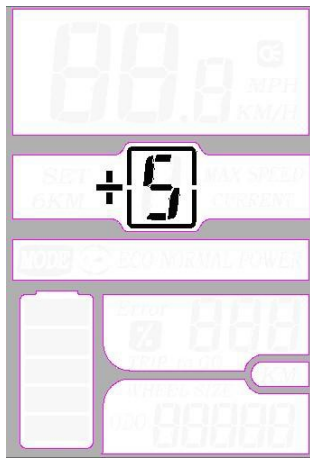

5. Battery Charge Display

When the battery is fully charged, the battery icon is filled. When the battery is in low voltage, the last check will flash, indicating the necessity to recharge the battery immediately.

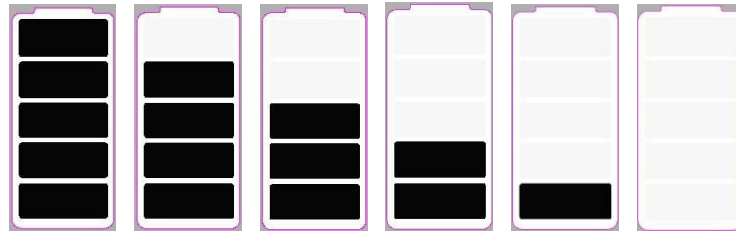

6 . Error Code Display

If there is something wrong with the electronic control system, the display will show the error code automatically. Refer to **Table 1** for detailed error code information.

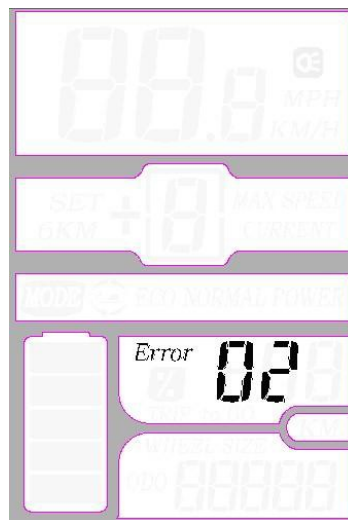

Error display interface can be exited only when the problems have been fixed.

General Settings

1、 Distance and Riding Time Clearing

- Press SET for 5 seconds to enter into TRIP distance display mode and press DOWN to clear Riding Distance.
- Hold **SET,UP** and **DOWN** for 5 seconds to clear Riding Distance and Total Distance.

2、 Wheel Size Setting

- Hold **SET** for 10 seconds to enter into wheel diameter setting interface.

Optional wheel diameter parameters include: 16, 20, 24, 26, 700C, 28. Press **UP** or **DOWN** to select the suitable diameter so as to ensure the accuracy of display about speed and mileage. Press SET to save current setting and exit the setting mode. **The wheel diameter is preset at the factory for your Trident E Spike.**

It is shown as below when the diameter is set at 700C:

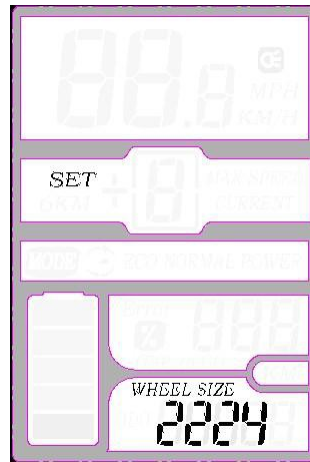

- Press **UP** or **DOWN** to choose the wheel diameter, Press **SET** to save the current setting and exit the setting mode.

3、KM/H, MPH Switching

Press **UP** and **DOWN** for 5 seconds to switch between KM/H and MPH. (Show KM/H at default)

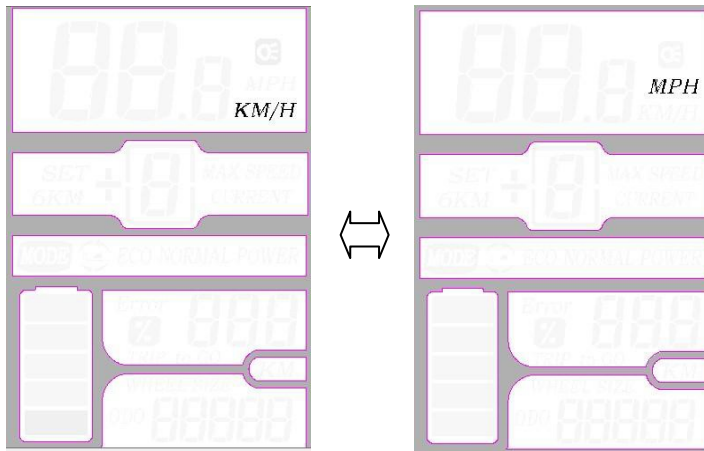

□ **Press SET to exit the above setting interface.**

FAQ

Q: Why the display is not able to start up?

A: Check the connector between the display wiring harness and controller.

Q: How to fix the error code?

A: Find the corresponding problem according to the error code table. If you are unable to fix it by yourself please call us or your Trident Trikes Dealer

Quality assurance and Warranty

Warranty

1、 Under warranty, Dapu will to provide limited warranty to any faults caused by the quality of the product under normal use.

2.The warranty period lasts for 12 months from the date of purchase.

Other items

The following items are not covered by the warranty

1. Disassembly or modification without authorization.
2. Malfunction or damage caused by the misuse or improper installation and debugging by the users or the third party.
3. Shell /Display scratches or breakage after delivery.
4. Wiring breakage.

CHUBUT PRECISE ELECTRONIC COMPANY LIMITED

Add: No.6101 LongDong Road He Qing Industry Zone Pudong New Area Shanghai

Tel: +86-021-58970723-178.

Fax: 021-58979066

Error code definitions

Corresponding error code is shown to indicate the malfunction:

Error code	Definition
2	Current Abnormality or Damage of Operating System
3	Motor locked up
4	Low voltage
5	Brake Sensor Abnormality
6	Motor Abnormality
7	Throttle Abnormality
8	358 Error
9	Over voltage (>45V)
10	Controller Communication Abnormality
15	Panel Communication Abnormality

Other Operating Tips:

Never use the charge indicator on the battery itself when it is installed, as it will make the display operate improperly. If you have done it, just slide the battery in and out to reset the system.

Sometimes in rare circumstances an error code will not clear. In this case open up the controller compartment at the front of the battery. Disconnect and reconnect each wire one by one. This often clears up any problem.

There is a fuse underneath the battery near the on off switch of the battery.

The rear light on the battery is run by AA Batteries- not the Lithium Ion Battery.

www.dapush.cn

CHUBUT PRECISE ELECTRONIC COMPANY LIMITED

Add: No.6101 LongDong Road He Qing Industry Zone Pudong New Area Shanghai

Tel: +86-021-58970723-178.

Fax: 021-58979066